

## DESCRIPTION

DATAKOM AVR-40 voltage regulator is an electronic device which lets the alternator to produce a fixed output voltage.

The device has open chassis, resin molded design and is intended to be mounted in the alternator's terminal box. The unit does not include moving parts; therefore it is able to operate in highly vibrating environments.

The device measures phase to neutral or phase to phase voltage of the alternator and adjusts the DC voltage applied to the excitation winding until reaching the desired voltage.

The unit offers low-frequency protection feature. A frequency measuring circuit continually monitors the generator output and provides output for low-frequency protection of the excitation system, by reducing the output voltage proportionally with frequency below a manually adjustable threshold. The nominal frequency can easily be changed to 50 or 60 Hz in the field by push-on link selection.

Sensing loss protection circuit terminates the excitation and protects the windings if there is no voltage on the sensing input.

The excitation power is derived directly from the generator terminals. The required minimum residual voltage for build up is 4 V-AC.

The output stage of the device is a Half Wave thyristor output associated with a free wheeling diode.

Basically the unit is compatible with all brushless type alternators. A stability adjustment potentiometer is also provided for this purpose.

A  $\pm 3V$  analogue input is provided allowing external voltage adjustment.

The AVR has the facility for droop CT connection, to allow parallel running with other similarly equipped generators.

An overload protection circuit limits the output current to its nominal value, preventing device failure under overload or short circuit condition.



## FEATURES

***Half-Wave thyristor output***

***Designed for highly vibrating environment***

***Built in voltage adjustment***

***Stability adjustment***

***Compatible with various types of alternators***

***External trimmer voltage adjustment input***

***Analogue voltage adjustment input***

***Droop input for parallel running***

***Sensing input provides phase-phase or phase-neutral control***

***Compatible for 50 and 60 Hz***

***Low frequency protection***

***Exciter over current protection***

***High Temperature protection***

***Sensing loss protection***



## INSTALLATION

**The unit is designed only for installation within other equipment by professional installers.**



**To avoid risk of shock, do not touch terminals and Heatsink which may have hazardous voltage.**

### VOLTAGE ADJUSTMENT

The generator output voltage is set at the factory, but can be altered using the VOLT potentiometer or by an external trimmer (if fitted). Terminals T1 and T2 on the AVR will be linked together if no external trimmer is used.



**Do not increase the voltage above the rated generator voltage.**

**Do not ground any of the trimmer terminals as these could be above earth potential.**

If voltage adjustment is required, proceed as follows:

1. Before running generator, turn the VOLT control fully anti-clockwise.
2. Turn external hand trimmer (if fitted) to midway position.
3. Turn STABILITY control to midway position.
4. Connect a suitable voltmeter (0-300V ac) across line to neutral of the generator.
5. Start the genset, and run on no load at nominal frequency e.g. 50-53Hz or 60-63Hz.
6. If the red LED turns on, refer to the Low Frequency adjustment.
7. Carefully turn VOLT control clockwise until rated voltage is reached.
8. If instability is present at rated voltage, refer to stability adjustment, then re-adjust voltage if necessary.
9. Voltage adjustment is now completed.

### STABILITY ADJUSTMENT

The stability potentiometer adjusts the reaction speed of the device. This helps the unit to comply with various alternators.

The correct setting can be found by running the generator at no load and slowly turning the stability control anti-clockwise until the generator voltage starts to become unstable. The optimum or critically damped position is slightly clockwise from this point.

### LOW FREQUENCY PROTECTION ADJUSTMENT

The low frequency protection circuit shuts off the excitation voltage in order to prevent damage during engine stopping under load. The factory set value for the protection is 45Hz. Turning the FREQ potentiometer anti-clockwise increases the set value. The red LED indicates that the Under-Frequency-Protection active.

### DROOP ADJUSTMENT

Generators intended for parallel operation are fitted with a quadrature droop Current Transformer(CT). The C.T. is connected to S1, S2 terminals on the AVR. The DROOP adjustment is normally preset in the factory to give maximum 10% voltage droop at full load. Turning the DROOP potentiometer anti-clockwise decreases the droop voltage.

### ANALOGUE ADJUSTMENT

An analogue input (A1 A2) is provided to connect devices which have analogue AVR control output. The input is designed to accept DC signals up to  $\pm 3$  volts.



**Any devices connected to this input must be fully floating and galvanically isolated from ground with an insulation capability of 500 V-AC. Failure to observe this could result in equipment damage.**

The DC signal applied to this input adds to the AVR sensing circuit. A1 is connected to the AVR ground. Positive on A2 increases excitation. Negative on A2 decreases excitation.

## TECHNICAL SPECIFICATIONS

### SENSING INPUT

Voltage 195-265 V-AC (L-N)  
340-450 V-AC (L-L)  
(see Connection Diagram)  
Frequency 50-60 Hz nominal

### POWER INPUT

Voltage 195-265 V-AC (L-N)  
Frequency 50-60 Hz nominal

### OUTPUT

Voltage max 90 V-DC at 207 V-AC input  
Current max 40 A-DC (continuous)

### REGULATION

± 1% (see note 1)

### THERMAL DRIFT

0.03% per °C change in AVR ambient (see note 2)

### TYPICAL SYSTEM RESPONSE

AVR response 20ms

### SOFT START

2 sec

### EXTERNAL VOLTAGE ADJUSTMENT

±10% with 2 k ohm 1 watt trimmer

### UNDER FREQUENCY PROTECTION

42-50 Hz or 52-60 Hz (adjustable)

### UNIT POWER DISSIPATION

18 watts maximum

### BUILD UP VOLTAGE

4 V-AC at AVR terminals

### ANALOGUE INPUT

±10% with ±3 V-DC (see note 3)

### QUADRATURE DROOP INPUT

Max. input: 5A  
Max. droop: 10% (adjustable)

### DIMENSIONS

Height: 80mm, Weight: 800gr

### ENVIRONMENTAL

Operating temperature -20 to +70 °C  
Maximum humidity 95% non-condensing.  
Storage temperature -30 to +80 °C

### NOTES

1. With 4% engine governing.
2. Heated up to 70°C
3. Any device connected to the analogue input must be galvanically isolated from ground, with an insulation strength of 500 V-AC.

## MECHANICAL DRAWING

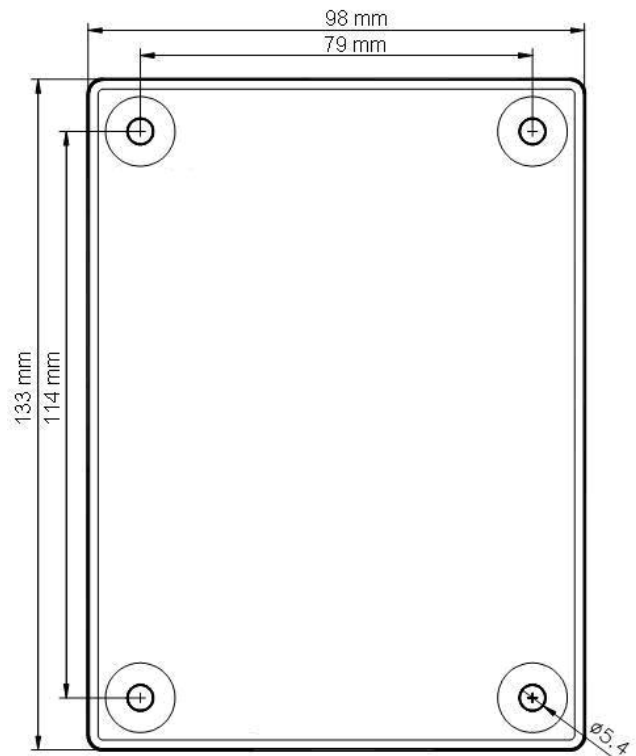

## WIRING

1. P : Alternator phase input.
2. N : Alternator neutral input.
3. P1, P3: Voltage sensing inputs. (Please refer to Connection Diagram)
4. T1, T2 : External trimmer terminals. Link if not required.
5. E+, E- : Excitation winding connections.
6. S1,S2 : Droop CT input terminal.
7. A1,A2 : Analogue controller input.
8. 60 HZ: Link for 60 Hz usage.

## CONNECTION DIAGRAM (PHASE - NEUTRAL SENSING)

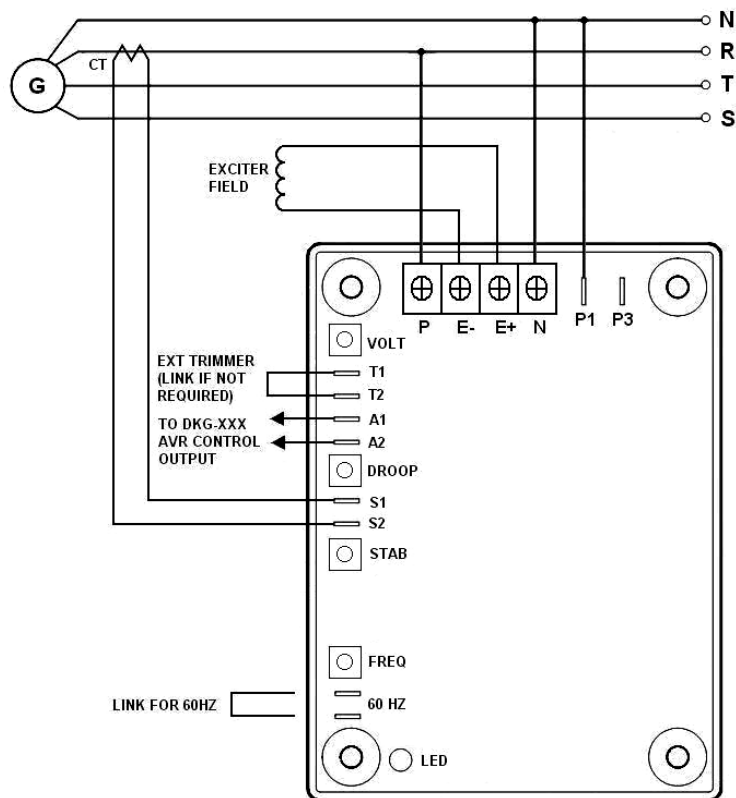

## CONNECTION DIAGRAM (PHASE - PHASE SENSING)

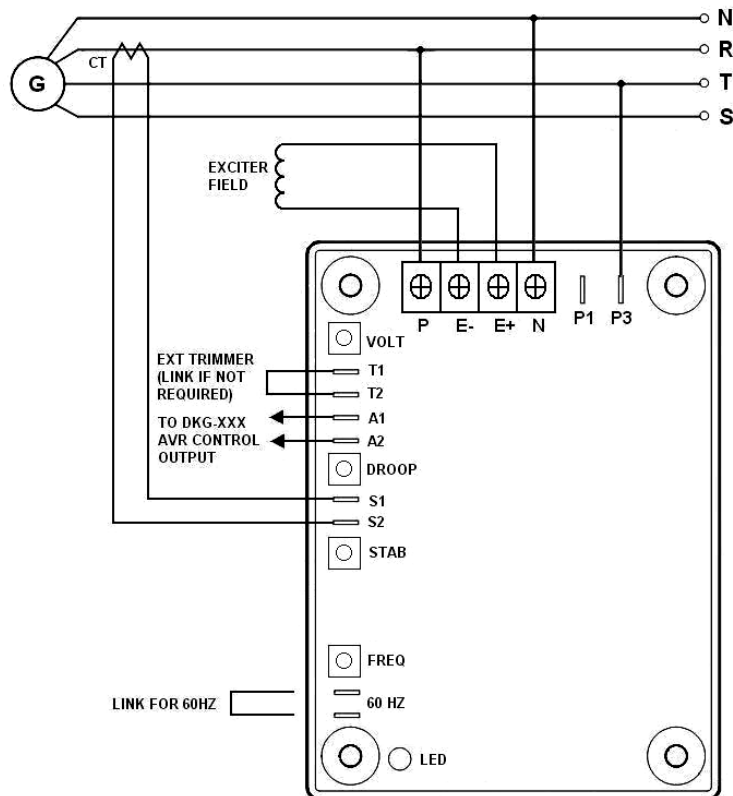

DATAKOM Electronics Ltd.

Tel: +90-216-466 84 60

Fax: +90-216-364 65 65

e-mail: datakom@datakom.com.tr

http: www.datakom.com.tr